

# BULLDOG 200Q/300Q STABILISER FITTING INSTRUCTIONS

These instructions must be passed onto the Stabiliser user.

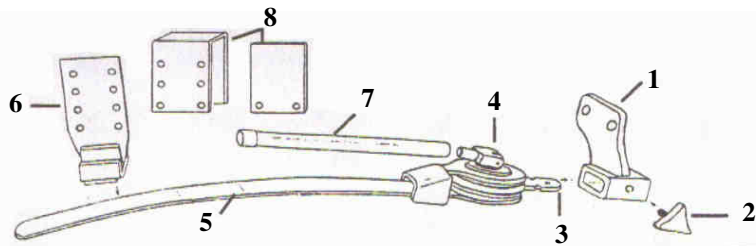

- 1) Reversible Car Plate
- 2) Locking Stud and dust cap
- 3) Damper pivot bracket
- 4) Cam lever and 12mm safety type adjusting bolt two lock nuts
- 5) Stabiliser spring arm
- 6) Angle bracket & slipper assembly
- 7) Tubular handle (detachable)
- 8) Saddle clamp c/w packer plates (2mm & 6mm thick)

**To Operate The Quick Release:** To release pressure on the Ferodo friction discs fit the tubular handle (7) on to cam spigot (4) and lift cam to vertical position. To apply pressure to the friction discs, simply press down until handle is horizontal, remove handle.

## Fitting To The Car

- 1) Remove the towing ball.
- 2) Determine which side, and fit the reversible car plate (1) between the towing ball and the car towing bracket (longer high tensile bolts may be necessary).
- 3) Lift the quick release cam (4) and insert damper pivot bracket (3) in to the slot in the reversible car plate (1) and secure with locking stud(2). To clear the caravan 'A' frame pull the stabiliser towards you.

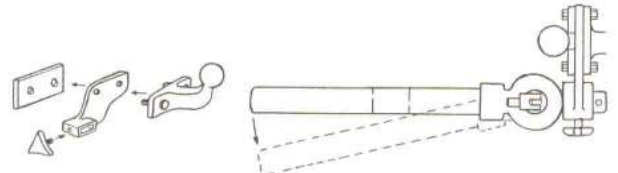

**Fitting To The Caravan With A Fairing:** When fitting the angle bracket (6) to an 'A' frame covered by a plastic fairing it is advisable to remove the fairing and fit directly to the metal frame. Then replace the fairing over the angle bracket.

## Fitting To The Caravan.

- 1) Load the car and caravan as normal and hitch up in line on a level surface. Please ensure the hitch is fully forward.
- 2) Push the stabiliser spring arm until it is parallel to the caravan 'A' frame.
- 3) Slide the angle bracket and slipper assembly (6) on to the spring arm leaving 4" (100mm) of spring protruding.
- 4) Holding the angle bracket vertical scribe marks down its edge on to the 'A' frame. Remove the bracket and pull aside the spring arm.

### 5a) Using Saddle Clamp Bracket Provided.

Alko Steel Chassis 40mm or 45mm wide and BPW Steel Chassis 46mm wide also 1993 Swift Conqueror Alko Chassis.

- i) Slide the saddle clamp bracket (8) over the chassis (tapped holes to the front) and position between the vertical pencil marks. **IMPORTANT.** On Swift Conqueror, or any other aluminium chassis, fit an insulator between saddle clamp bracket and chassis e.g. Bulldog rubber strip part No LC27.
  - ii) Engage angle bracket assembly (6) under spring and push to 'A' frame.
  - iii) Lock up quick release and lift spring arm at end between 1.5" to 2.5" (40 to 65mm). Note which row of holes in angle bracket line up with bottom holes in saddle clamp bracket.
  - iv) Fit the angle bracket to the bottom set of holes with the two M8 x 75 long bolts and lock nuts provided.
    - Alko 40mm wide chassis:- Fit 6mm packer plate between saddle clamp and outer face of chassis.
    - Alko 45mm wide chassis:- Fit 2mm packer plate between saddle clamp and outer face of chassis.
    - BPW 46mm wide chassis:- Omit packers.
  - v) Fit one serrated M8 washer and one plain washer over each of the two M8 x 16 set pins.
  - vi) Screw set pins through top two holes in angle bracket.
  - vii) Tighten the two long bolts and nuts and the two set pins evenly (do not over tighten).
- Bulldog manufacture other saddle clamps specifically designed to fit Lunar and Swift Chassis caravans. Please refer to dealer for full list.

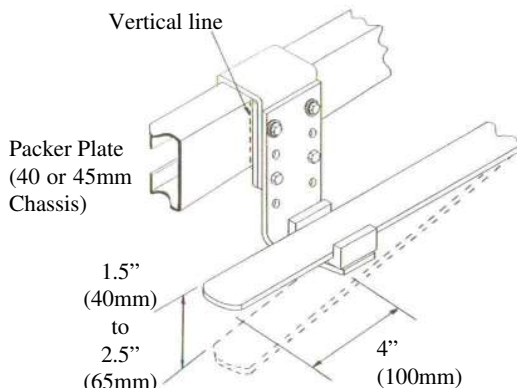

### 5b) Fitting To Chassis Where Drilling is possible. (Refer to Caravan handbook).

Follow fitting to the caravan steps 1 to 4 then:

- i) In the approximate position of the angle bracket on the 'A' frame draw a horizontal centre line equal distance from the top and bottom flanges.
- ii) Position the angle bracket vertical to the lines marked on the 'A' frame and mark through any two holes on to the centre line. Remove the bracket.
- iii) Drill two 8.5mm holes.
- iv) Slide angle bracket back on to spring arm and push to 'A' frame.
- v) Lock up quick release and lift spring arm at end between 1.5" and 2.5" (40 to 65mm) and insert two M8 x 30 bolts through the appropriate holes and bolt up with nuts and washers. Tighten evenly.

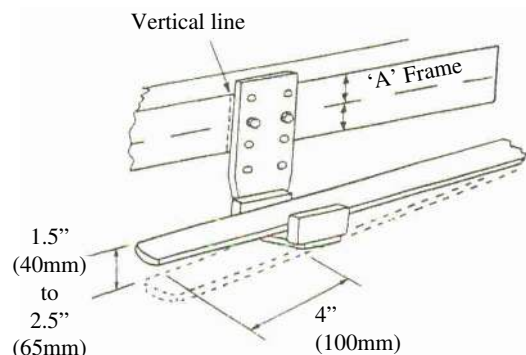

## Adjustments.

- 1) After fitting ensure that full turning clearance is obtained both ways and that the spring is completely retained in the plastic slipper.
- 2) The stabiliser is factory set but may need adjustment after use.
- 3) To adjust the friction damper assembly you will require the following tools:
  - A set of bathroom scales or suitable spring balance.
  - Two open ended 19mm spanners.

**Note. Adjustment is carried out with quick release locked i.e. pressure applied to friction discs.**

## IMPORTANT!

Please **DO NOT** use torque wrench as the torque needed on the 12mm adjusting bolt and nut (4) is very small.

- 4) Insert the damper pivot bracket (3) into the slot in the car plate (1) and secure with locking stud(2).
- 5) Apply the scales to the end of the spring arm and push. You are looking for a reading on the scales of approximately 60lbs (27kg).

It is emphasised that this is NOT a torque figure but the horizontal push/pull force at the end of the spring arm.

6) Adjustment is made by releasing the thin lock nut on the 12mm centre bolt and tightening up the special type lock nut until the appropriate reading is obtained on the scale. Finally, firmly lock up the special nut and thin lock nut together using the two spanners. Take care not to move the special nut on the bolt or you may lose the correct setting. Check tightness of the thin lock nut after 50 miles.

- 7) **DO NOT USE ANY OTHER METHOD FOR CHECKING THE STABILISER.**

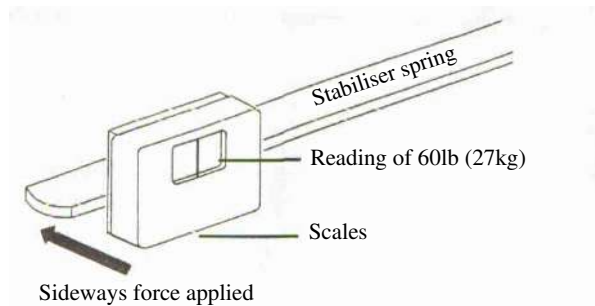

If you have any doubt about servicing your stabiliser please contact your nearest dealer or telephone Bulldog for assistance.

## WARNING!

After fitting and prior to commencing your journey, please check tightness of the locking stud holding the Stabiliser into the car bracket. A secondary safety and security feature of the Bulldog Stabiliser is the provision of a hole in the end of the damper pivot plate (3). This is to facilitate the use of a padlock (not supplied).

### When Boarding Ferries or Off Road on Uneven Ground.

It is advisable to remove stabiliser to avoid damage to the spring arm.

### When Not In Use.

Remove locking stud. Apply grease in the thread car bracket and fit Red Cap. To remove cap just unscrew.

### When Towing Very Heavy Trailers.



## Bulldog Security Products Limited

Units 2,3,4 Stretton Road, Much Wenlock, Shropshire, TF13 6DH.

Tel: 01952 728171 Fax: 01952 728117

## Replacing Friction Discs.



**Friction Head Parts Layout 200Q**

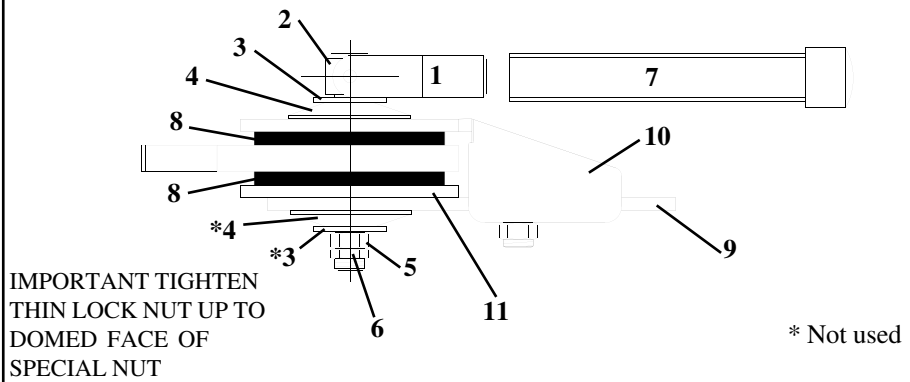

- 1 - Cam Release
- 2 - Retaining Bolt with Safety Head
- 3 - Retaining washer
- 4 - Disc Spring
- 5 - Special Locking Nut
- 6 - Thin 12mm Lock Nut
- 7 - Tubular Detachable Handle
- 8 - Friction Discs
- 9 - Spring Blade
- 10 - Top Plate
- 11 - Bottom Plate

The Bulldog specially developed Ferodo friction discs will last many thousands of miles if the stabiliser is maintained correctly. However, replacing worn discs is very straight forward.

1. Fit tubular handle over cam lever then using a 19mm spanner undo the thin lock nut on the 12mm centre bolt, undo the full lock nut next.
2. Dismantle the damper assembly taking care to note the position of each of the washers and disc springs.
3. Examine the surfaces of each of the metal plates and scrape off any build up of friction material. Do not score the faces where the friction discs operate. Do not use oils or chemicals for cleaning off dust. Avoid breathing in dust, although Bulldog friction discs do not contain asbestos.
4. Using a straight edge, check the pivot plate has not been damaged.
5. Re-assemble new genuine Bulldog friction discs (Part No LC3-3 for 200Q and 400Q. Part No LC65 for 100Q) into the stabiliser damper assembly and re-fit lock nuts.
6. Refer to section on adjustments to re-set the correct spring tension.

### Care of Your Stabiliser

1. When boarding ferries or travelling off road on uneven ground it is advisable to remove the stabiliser from the towing vehicle to avoid damage. Do not allow the stabiliser to 'ground out' i.e. Touch the road, or speed ramps etc, the weight transfer from the car and caravan to the underside of the stabiliser can damage the main pivot plate.
2. Do not leave the stabiliser attached to the car when unhitched from the caravan. If the stabiliser contacts the ground whilst manoeuvring and digs in, severe damage can occur to stabiliser, towbar bracket and towbar.
3. When the stabiliser is not in use, remove the locking stud and apply grease to the thread in the car plate and then fit the red plastic protective cap to the threaded hole. If the thread becomes damaged and the locking stud is difficult to insert, then the car plate can be re-tapped using M12 x 1.5 tapping tool. (Your local engineering shop should be able to help).
4. Do not allow the friction discs to become contaminated with oil. Never lubricate the friction discs. Oil on the friction discs will ruin the friction characteristics.
5. Regularly check the condition of the slipper bracket attached to the caravan chassis for wear and /or damage and replace if necessary.

### **Bulldog Security Products Limited**

Units 2,3,4 Stretton Road, Much Wenlock, Shropshire, TF13 6DH. Tel: 01952 728171 Fax: 01952 728117  
email: [sales@bulldogsecure.com](mailto:sales@bulldogsecure.com) Web Site: <http://www.bulldogsecure.com>