

# CAMOS

## CSA-2300M / CSA-2400M

Full automatic, auto-tracking Satellite antenna

### Instruction Manual

Ver. 1.5

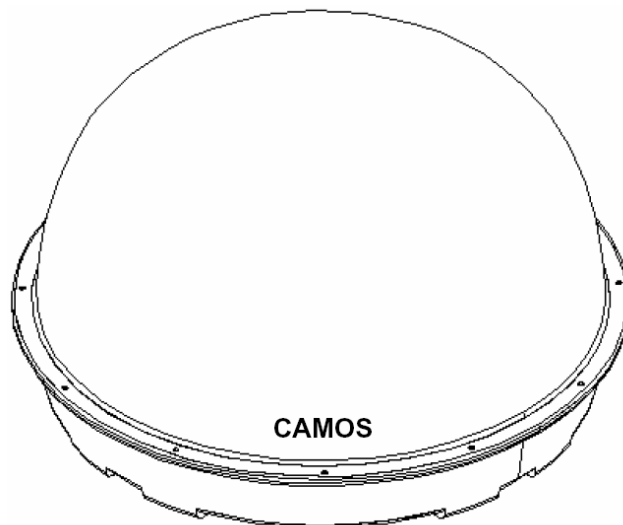

**Thank you for purchasing our product.  
Please read this instruction manual carefully before mounting  
and operating this antenna!**

**Pls write down the serial number of this antenna.  
In case of questions pls inform us of this number:**

**Ser.-Nr.:** \_\_\_\_\_

The Camos CSA-2300M / CSA-2400M enables reception on the move of the major European satellites like ASTRA 2, ASTRA 1, HOTBIRD , SIRIUS, AB3, Thor and Hispasat. If you want to watch TV or access the Internet via satellite, even when your vehicle is moving, here's the equipment you need. The sat-dome is compact in size, light in weight, reliable in operation and incredibly easy to operate and install: there's just one co-ax cable to run.

Even if the in-motion facility isn't needed, the system's simplicity and neatness makes it an attractive alternative to conventional dish systems.

Two sizes are available: both have the same diameter but differ in height. The larger model (CSA-2400M) is designed for use in areas which are outside the central area of a satellite's footprint.

## 1. Standard accessory

- Sat-Antenna CSA-2300M / CSA-2400M
- Control box incl. power cable
- 1 HQ co-ax cable (10m) with F-plug on both ends
- 1 HQ co-ax cable (1m, black)
- 1 Gel protection cap for F-plug

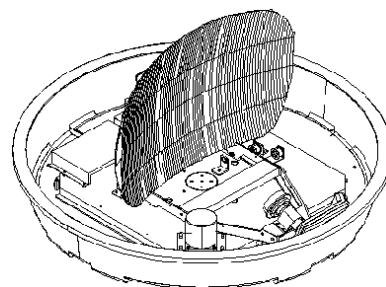

## 2. Installing your antenna

**We basically recommend installing the CSA-2300/CSA-2400 with the help of your professional dealer/workshop!**

**Pls pay attention that installing the antenna increases the height of your vehicle!**

**Important!**

**Pls absolutely keep to each individual point of mounting instruction!**

**General:**

Pls take care of a suitable workplace, a garage or hall is better than a place outside. The ambient temperature during sticking the antenna should lie within a temperature between +5°C to max.+25°C. If you work outside **avoid direct sunlight!**

Always keep to the instructions dealing with chemical products.

Take care of necessary hygienic working conditions.

**Preparation:**

1. Assure that the roof of your vehicle is able to carry the antenna. If you are not sure pls fix a metal plate (Alu, appr. 2mm thickness) onto the roof. Pls also ask the vehicle's manufacturer.
2. Pls check completeness of parts.
3. Put the antenna on the selected mounting place on the car roof and adjust if necessary. The mounting place must be even and no other roof constructions may cover the reception area of the antenna.  
Mark the outline of antenna feet with a suitable pen.  
In case of problems (e.g. the roof is not even but has a curved form instead) pleas call our hotline to arrange further steps.



4. Replace the antenna.

Clean the mounting place and the antenna feet with the supplied special cleaning fluid "Reiniger1" and the supplied fleece (pls wear the supplied Latex gloves!). Grind the marked fixing areas and antenna feet with sandpaper (not too much, the surface must be rough a little bit only), clean the surface and antenna feet with cleaning fluid 1 again and wait another 10 minutes.

**Attention! Now do not touch the cleaned surface any more!**

5. Apply (with the help of the wool wiper - pls wear the supplied Latex gloves!) the Primer 2 evenly and thin onto the cleaned surface and feet. Then pls wait another 10 minutes. **Attention! Do not touch the cleaned surfaces any more!** Close the Primer 2 bottle at once after use.

**Note:**

If the surface of the mounting place is made from unknown material, we recommend a "test sticking". If necessary we can arrange a material analysis at your cost.

**Sticking the antenna to your vehicle's roof:**

1. Cut the tip of the supplied cartouche special glue "Spezialkleber 3" (pls wear the supplied Latex gloves!).
2. Apply evenly the glue onto the antenna feet (thickness of glue layer appr. 3 to 4mm)
3. Pls put the antenna (max. 5 minutes after applying the glue!) on the selected mounting place on the car roof. Press the antenna feet smoothly onto the roof and fix the antenna with tape e.g. to avoid moving. After pressing the antenna feet onto the roof the minimum thickness of the glue layer must be appr. 2mm.  
Now the glue needs a hardening time of appr. 48 hours (air humidity of 50%).  
If the air humidity is lower than 50% pls spray some water into the air in the surrounding of the antenna feet.
4. Remove the outcropped glue on the sides of antenna feet and clean the surface with the supplied fleece and special cleaning fluid "Reiniger1".
5. In addition you can fix the antenna feet with the help of 4 screws. Pls set the screw **after** hardening of the glue.

### 3. Connections

**Do not mount the Control box and your satellite receiver in the area of the vehicle's airbags!**

**Lay the cables carefully to avoid short circuit! Pay attention to existing cables!**

1. Connect the antenna by plugging the long white cable into antenna and control box.
2. Put the gel cap over the antenna socket.

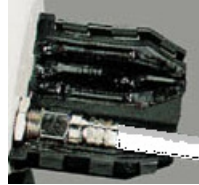

Gel cap

3. Connect the power cable (red/black) to the control box and power source (car battery e.g.). Positive terminal (+) = red colour  
Negative terminal (-) = black colour

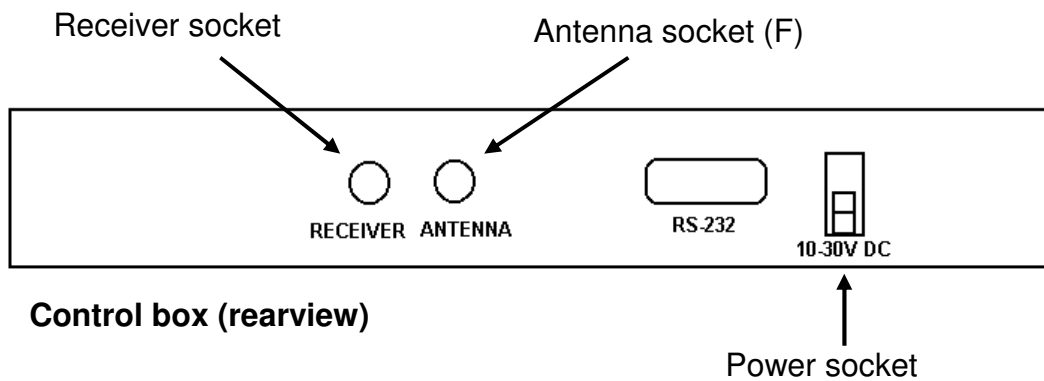

4. Install your satellite receiver according to its user manual and connect it to the control box via the short white co-ax cable.

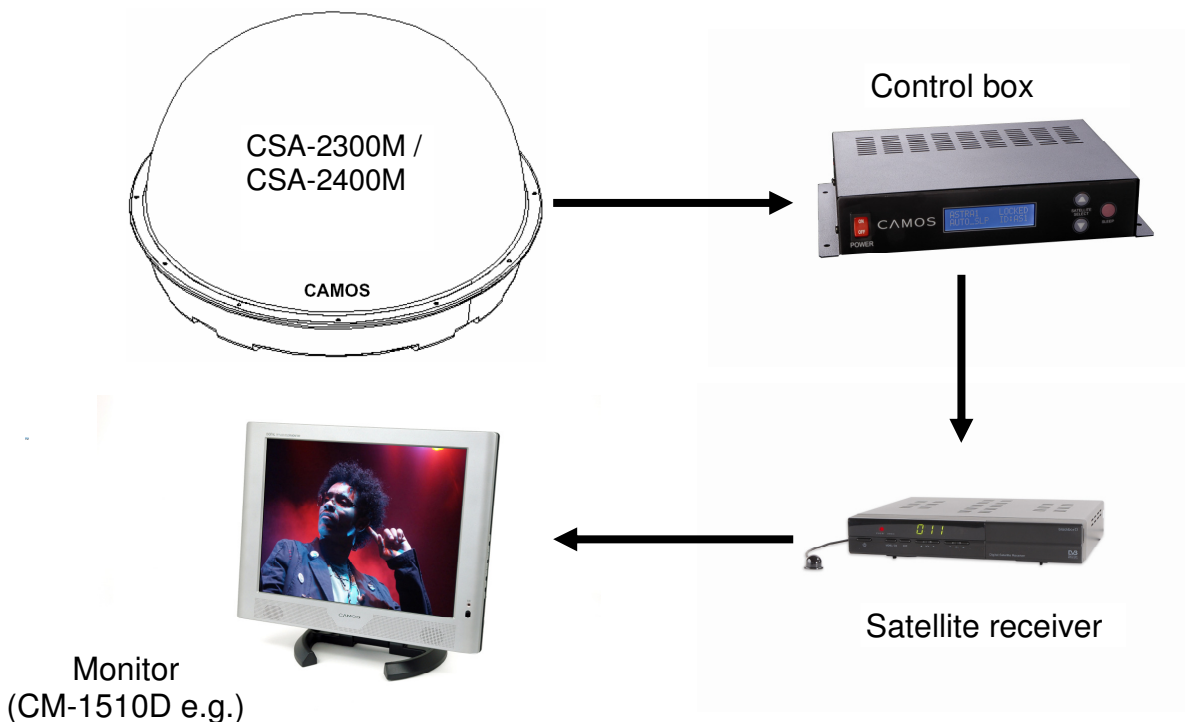

## 4. Starting up

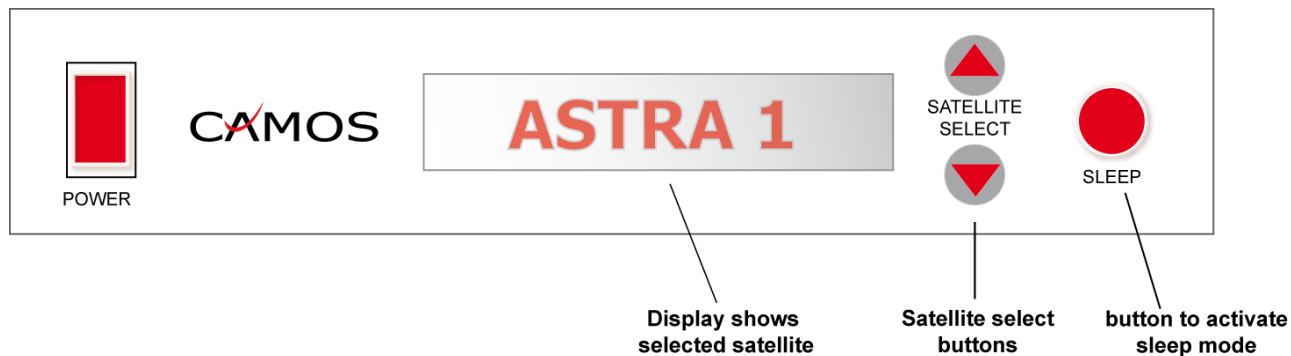

1. Switch on your satellite receiver and monitor/TV. Then switch on the control box.
2. The antenna goes to search mode and, after a while, finds the desired satellite.

## 5. Operating the antenna

### 1. Selecting a satellite / Search mode

Push the "SATELLITE SELECT" button several times until the desired satellite indicator lights up.

**ASTRA 2-N** Select this position when you are in the northern part of ASTRA2 footprint.

**ASTRA 2-S** Select this position when you are in the southern part of ASTRA2 footprint.

**ASTRA 1** Select this position for Astra 1

**HOTBIRD** Select this position for Hotbird

**SIRIUS** Select this position for Sirius

**Thor** Select this position for Thor 2/3

**AB 3** Select this position for Atlantik Bird 3

**HISPA** Select this position for Hispasat

Now the antenna starts searching and the indicator for the search mode (SEARCH) lights up.

## 2. Tracking mode

When the antenna has found the selected satellite, the satellite indicator goes out for 1 second and lights up again. Now the satellite is logged in and the tracking indicator (TRACKING) lights up.

Sometimes it happens that the antenna at first stops and locks onto a different satellite (depending on your position, signal strength and weather conditions). In this case the indicator of the different satellite lights up for a second and goes out again. The antenna has now recognized that it has found the wrong satellite and moves to the correct position.

The controller will remember which satellite it last found and will always look for that one when it is switched on again.

Now you can enjoy TV.

## 3. Standby / Sleep mode

When your vehicle does not move for a longer time (antenna keeps position), the antenna automatically falls into a "Sleep" mode (Standby). That means the tracking movements will be stopped (to avoid tracking noise).

If the antenna position is changed (boat starts moving again) the antenna automatically starts the tracking mode (TRACKING) or search mode (SEARCH), depending on how much the antenna position has changed.

You can also manually activate the standby / sleep mode:

After logging in (TRACKING mode indicator lights up) push the "SATELLITE SELECT" button once. Now the SLEEP mode indicator lights up in addition and the antenna stops moving.

You can deactivate the SLEEP mode by pushing the "SATELLITE SELECT" button once again.

If you completely switch off the antenna (e.g. overnight) the antenna will go to search mode again after switching on the next day.

## 6. In case of problems

No reception / no picture:

- a) Any obstacles (trees, buildings or roof constructions) between antenna and satellite?  
Choose a different position or wait until your vehicle is in reception area of satellite again.
- b) Correct installation of antenna cables? Defective cables (broken)?  
Pls check the cables!
- c) Did you select the right satellite? Pls check whether the satellite you have selected in your receiver corresponds with the satellite you have selected on control box.
- d) Did you switch on control box and satellite receiver?
- e) Power supply ok? Pls check power cable(s).

### **If you want to use a different cable (from antenna to control box):**

Pls only use high quality and low loss co-ax cable. The F-plugs must be high quality types as well, because besides the RF signal the power supply voltage for antenna passes this cable. Minimum losses may have an effect on reception.

We strongly advise to use the supplied cables.

## 7. Technical Data

Frequency range:	10,7 to 12,75 GHz
LNB-Type:	universal
Polarisation:	horizontal and vertical
Gain:	33dBi
Elevation:	17° - 60°
Azimuth:	not limited
Power supply:	12 - 30V / appr. 27W max.
Operating temperature:	-22 °C to +55 °C
Diameter:	appr. 69,5cm
Height:	appr. 30cm (CSA-2300M) appr. 40cm (CSA-2400M)
Weight (without control box):	10,1kg (CSA-2300M) / 10,4kg (CSA-2400M)

IMC GmbH (Camos Europe)  
Carl-Zeiss-Str. 7  
D-22946 Trittau  
GERMANY

Tel 04154 / 8083 - 0  
[www.camos-multimedia.com](http://www.camos-multimedia.com)  
[info@camos-multimedia.com](mailto:info@camos-multimedia.com)